



Otter XT Resort Installation and Set-Up Instructions

Otter XT Resort Fits Large Otter II & Pro Sled Only Parts Identification and Check List

MODEL NUMBERS:

Complete Pkg Otter XT Resort 200964

PARTS LIST

Item #	Qty	Part #	Description
1	1	200821	Sled - Black
2	1	200973	Tent - XT Resort
3	1	80172	Frame Bracket "A"
4	1	80171	Frame Bracket "B"
5	2	80548	Back Wind Support Bar - 49"
6	2	80546	Center Wind Support Bar - 37 5/8"
7	2	80547	Center Wind Support Bar - 49"
8	2	80549	Adjustable Front Wind Support Bar
9	2	80540	Main Frame Extension Bar - 34"
10	2	80541	Main Frame Extension Bar - 35 1/4"
11	4	80542	Main Frame Extension Bar - 29"
12	4	80544	Outer Main Frame Bar - 36 3/4"
13	2	80543	Outer Main Frame Bar - 32 5/8"
14	4	80545	Middle Main Frame Bar - 61 3/4"
15	2	80550	Outer Main Frame Bar - 32"
16	8	200384	Sleeve
17	16	400641	Self Tapping Screw #8 x 3/4"
18	8	200197	Black Plug
19	8	200195	Black End Cap
20	4	200615	5/16 Washer
21	12	400648	1/4 Nylon Hex Lock Nut
22	12	200942	3/8" Self Tapping Screw
23	16	200941	Plastic Protector
24	16	200943	Star Washer
25	1	200982	Plastic Trim Lock Kit

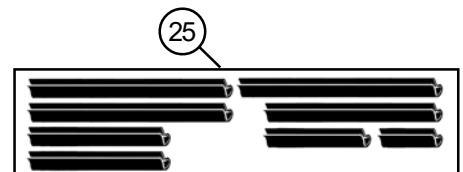
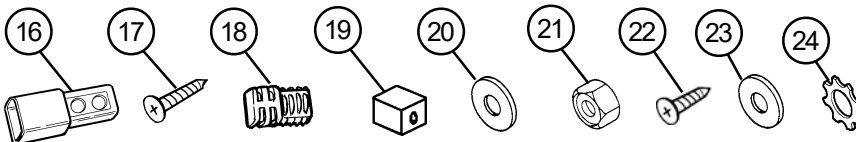
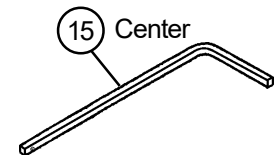
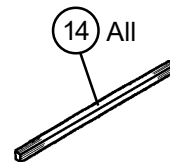
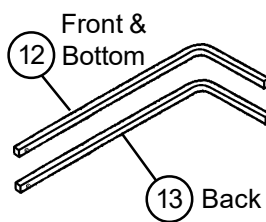
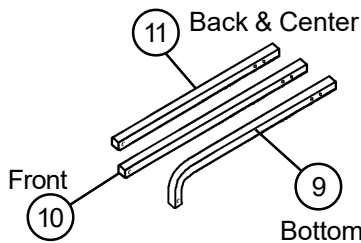
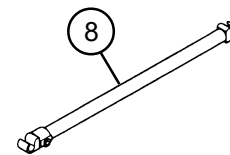
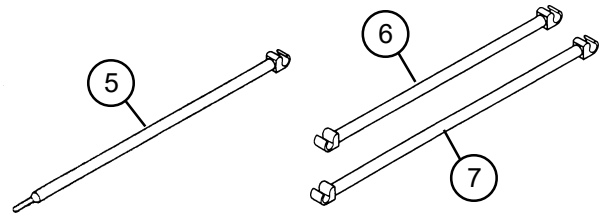
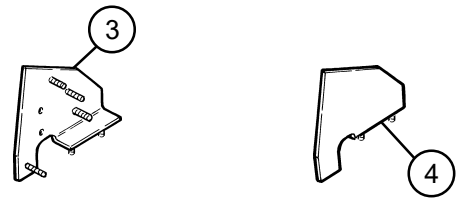
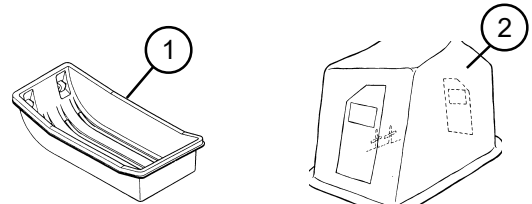

Tools Required:

7/16 Box End Wrench 7/16" Drill Bit
7/16 Socket and Ratchet 5/16" Drill Bit
Drill

1. Layout all parts.

Diagram 1

2. Position sled (Item 1) as shown in Diagram 1, with curved front to your left.

3. Tip sled on its side and drill the 4 marked holes using a 5/16" drill bit.

4. Using the premarked holes, drill the 7/16 in. holes in center of lip near the bend in sled. The back wind support bars (Item 5 not shown) are to be propped here.

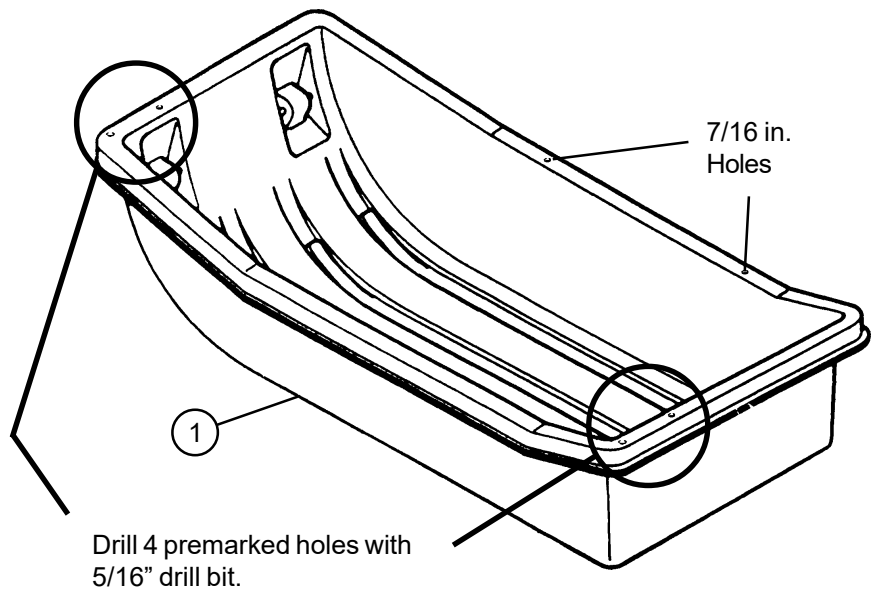

5. Bolt frame brackets (Item 3 and Item 4) to sled using holes predrilled in Step 3. Use appropriate fasteners shown in Diagram 2.

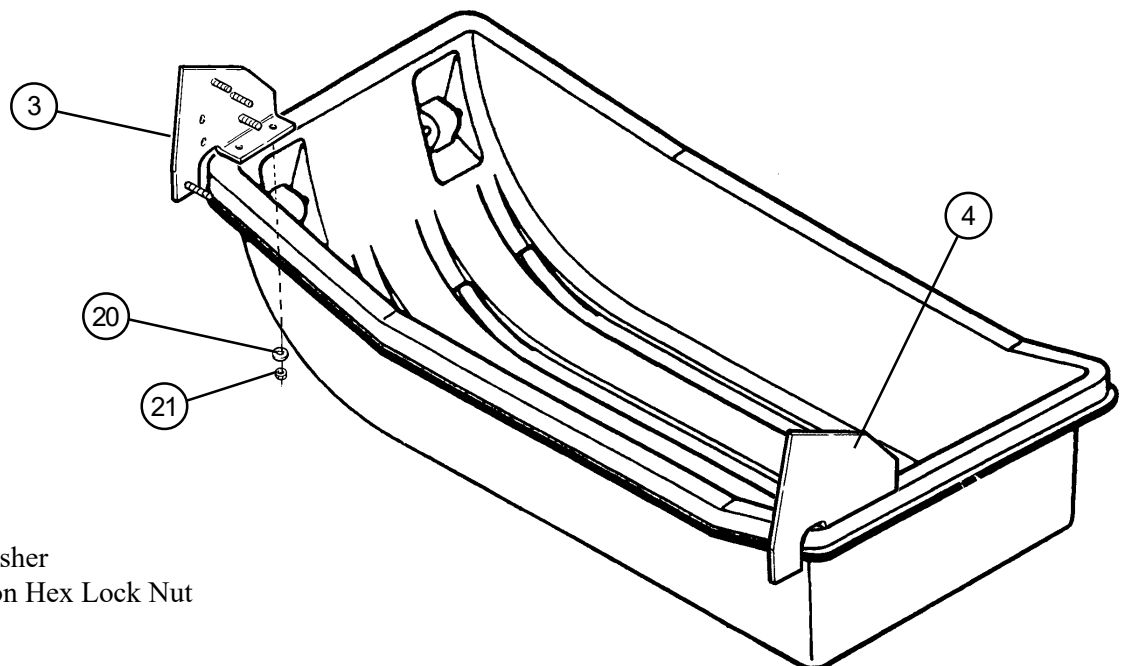
Diagram 2

Item 20- 5/16 Washer

Item 21- 1/4 Nylon Hex Lock Nut

6. Assemble **Back Main Frame Bar**: Insert the outer main frame bar (Item 13) into the middle main frame bar (Item 14). Fasten with self-tapping screw (Item 17), plastic protector (Item 23), and star washer (Item 24). Slide the sleeve (Item 16) over the main frame extension bar (Item 11). **(Line up holes with button lock, press lock in as you slide over the bar)**. Insert the black plug (Item 18) into the main frame extension bar (Item 11). Insert outer main frame bar (Item 13) into sleeve (Item 16). Cover end of main frame extension bar (Item 11) with black end cap (Item 19). Ref. Diagram 3.

Diagram 3

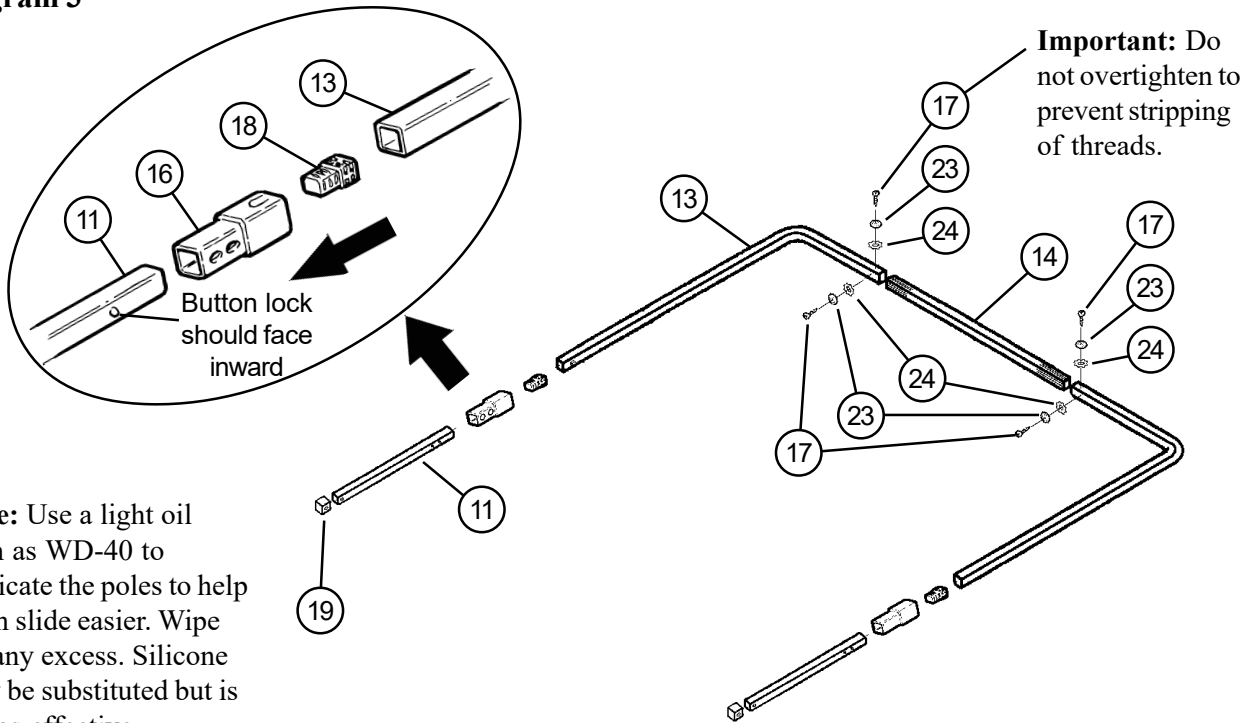

Note: Use a light oil such as WD-40 to lubricate the poles to help them slide easier. Wipe off any excess. Silicone may be substituted but is not as effective.

7. Attach **Back** main frame assembly (Assembled in Step 6) onto frame brackets (Item 3 and 4). Secure with 1/4 nylon hex lock nut (Item 21). Ref. Diagram 4.

Diagram 4

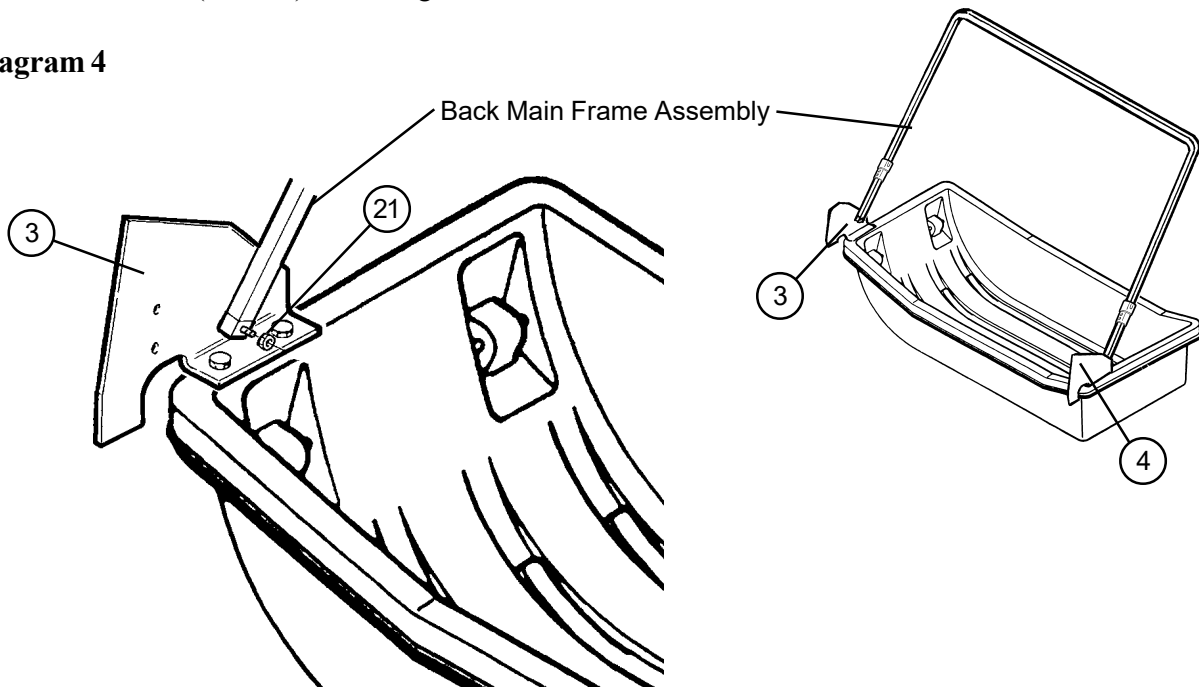

6. Assemble **Center Main Frame Bar**: Insert the outer main frame bar (Item 15) into the middle main frame bar (Item 14). Fasten with self-tapping screw (Item 17), plastic protector (Item 23), and star washer (Item 24). Slide the sleeve (Item 16) over the main frame extension bar (Item 11). **(Line up holes with button lock, press lock in as you slide over the bar)**. Insert the black plug (Item 18) into the main frame extension bar (Item 11). Insert outer main frame bar (Item 15) into sleeve (Item 16). Cover end of main frame extension bar (Item 11) with black end cap (Item 19). Ref. Diagram 3A.

Diagram 3A

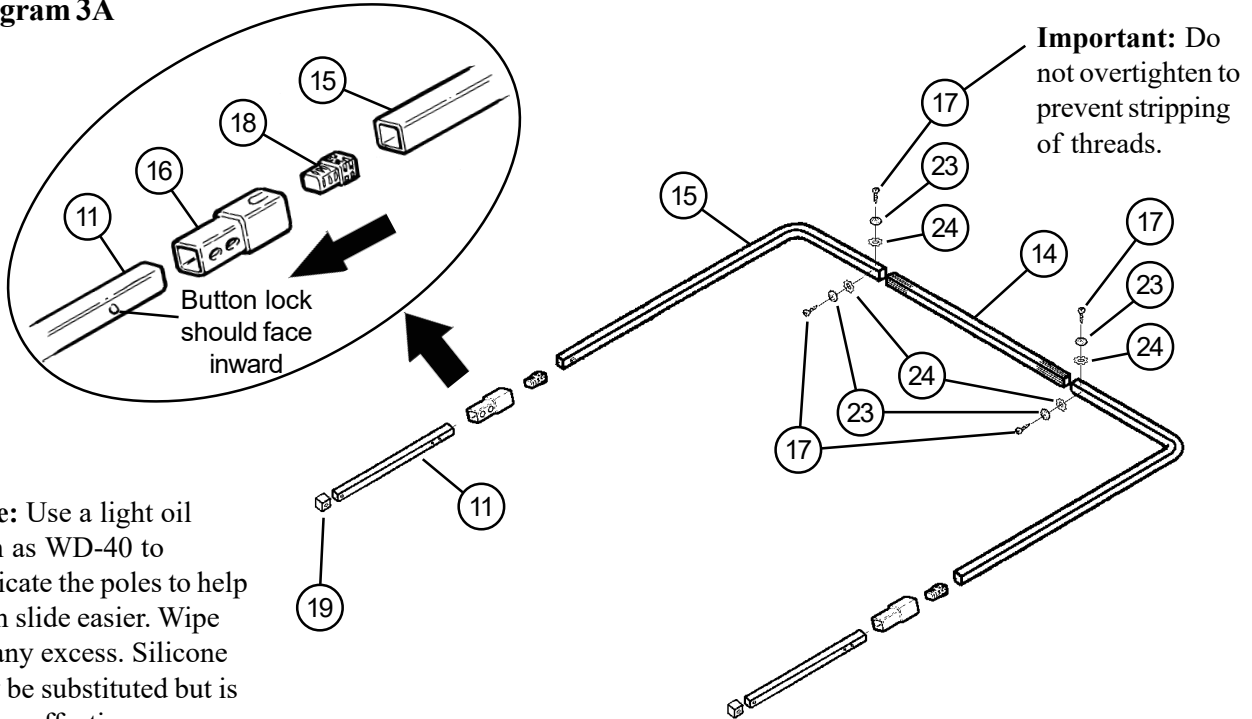

Note: Use a light oil such as WD-40 to lubricate the poles to help them slide easier. Wipe off any excess. Silicone may be substituted but is not as effective.

7. Attach **Center** main frame assembly (Assembled in Step 6) onto frame brackets (Item 3 and 4). Secure with 1/4 nylon hex lock nut (Item 21). Ref. Diagram 4A.

Diagram 4A

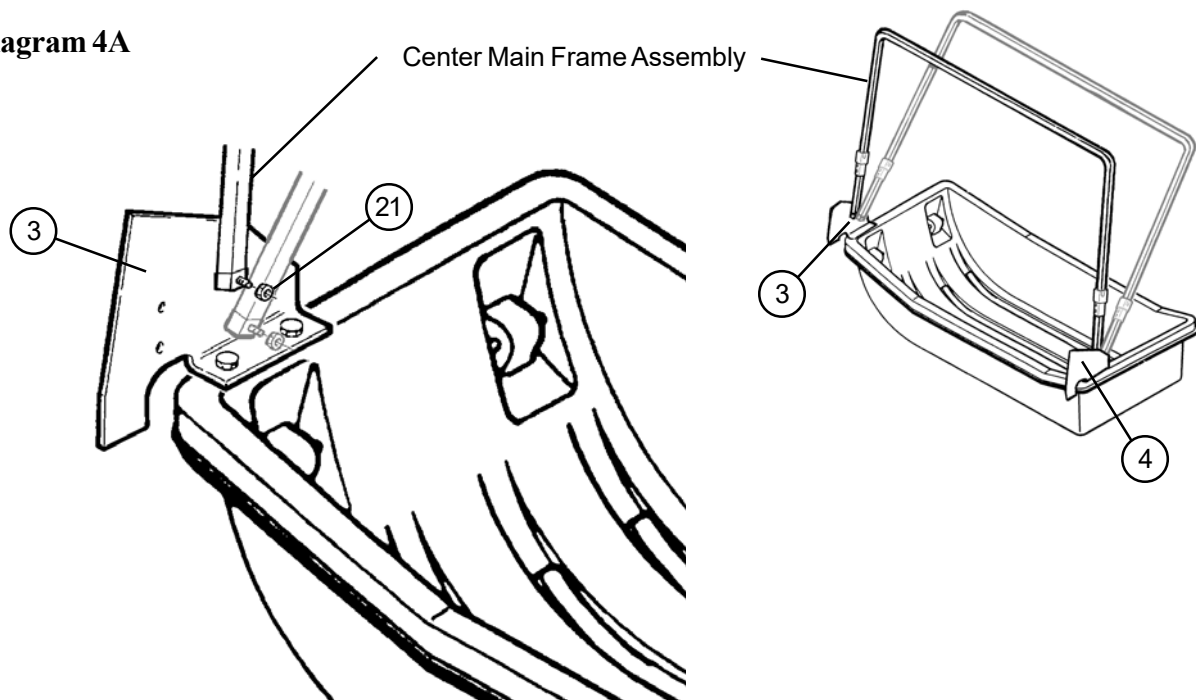

8. Assemble **Front Main Frame Bar**: Insert the outer main frame bar (Item 12) into the middle main frame bar (Item 14). Fasten with self-tapping screw (Item 17), plastic protector (Item 23), and star washer (Item 24). Slide the sleeve (Item 16) over the main frame extension bar (Item 10). **(Line up holes with button lock, press lock in as you slide over the bar)**. Insert the black plug (Item 18) into the main frame extension bar (Item 10). Insert outer main frame bar (Item 12) into sleeve (Item 16). Cover end of main frame extension bar (Item 10) with black end cap (Item 19). Ref. Diagram 5.

Diagram 5

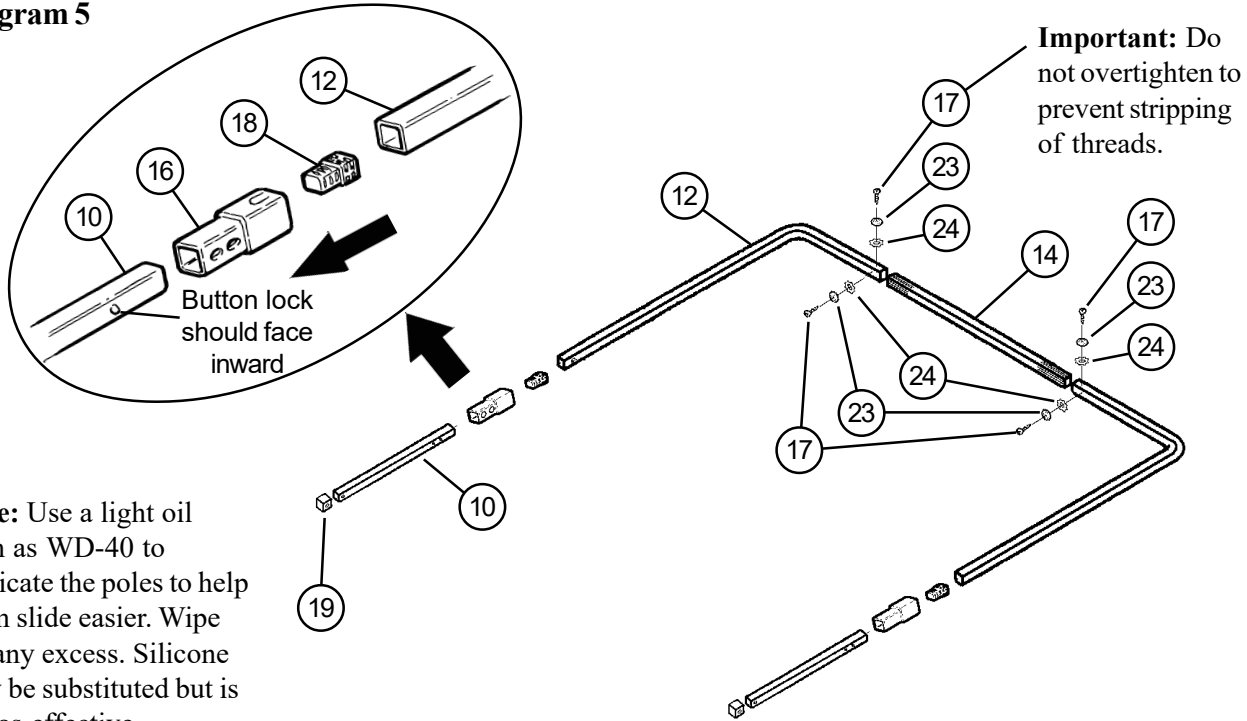

Note: Use a light oil such as WD-40 to lubricate the poles to help them slide easier. Wipe off any excess. Silicone may be substituted but is not as effective.

9. Attach **Front** main frame assembly (Assembled in Step 8) onto frame brackets (Item 3 and 4). Secure with 1/4 nylon hex lock nut (Item 21). Ref. Diagram 6

Diagram 6

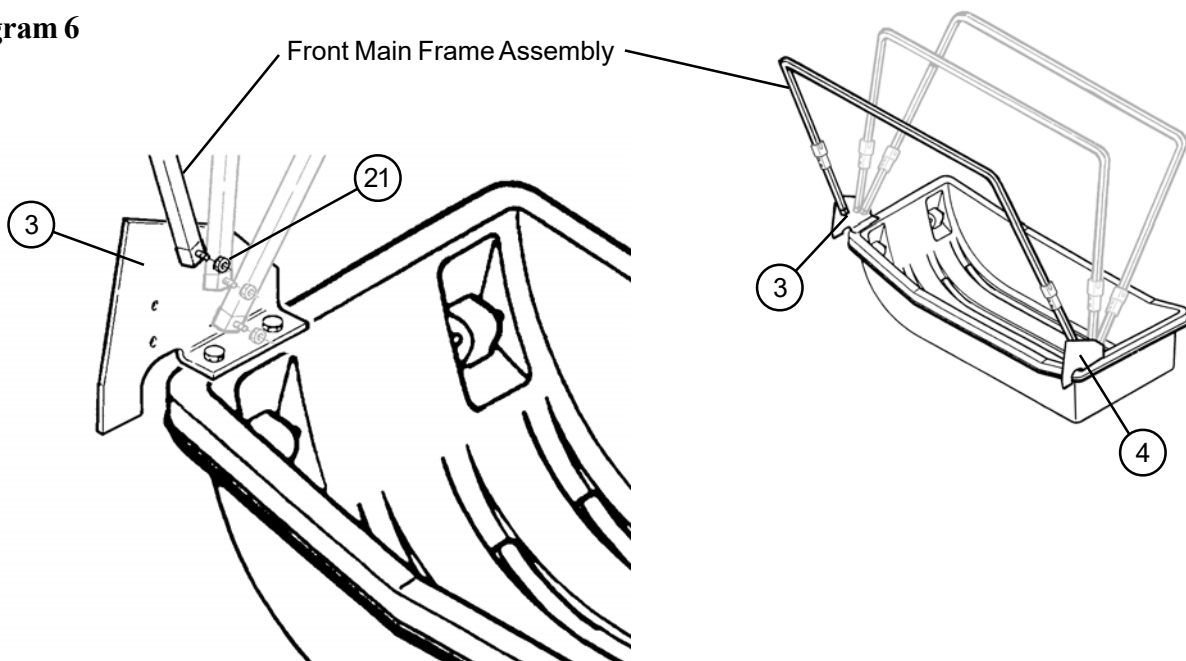

10. Assemble **Bottom Main Frame Bar**: Insert the outer main frame bar (Item 12) into the middle main frame bar (Item 14). Fasten with self-tapping screw (Item 17). Slide the sleeve (Item 16) over the main frame extension bar (Item 9). **(Line up holes with button lock, press lock in as you slide over the bar)**. Insert the black plug (Item 18) into the main frame extension bar (Item 9). Insert outer main frame bar (Item 12) into sleeve (Item 16). Cover end of main frame extension bar (Item 9) with black end cap (Item 19). Ref. Diagram 7.

Diagram 7

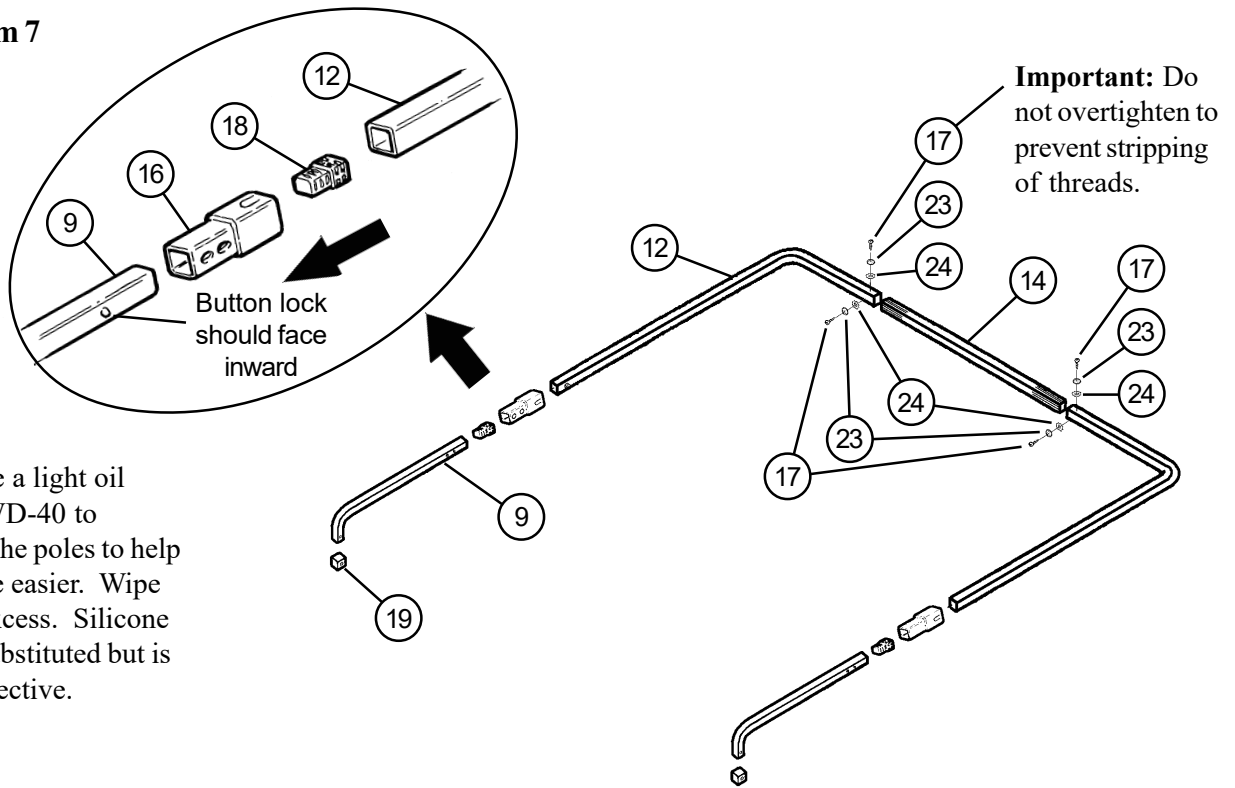

Note: Use a light oil such as WD-40 to lubricate the poles to help them slide easier. Wipe off any excess. Silicone may be substituted but is not as effective.

11. Attach **Bottom** main frame assembly (Assembled in Step 8) onto frame brackets (Item 3 and 4). Secure with 1/4 nylon hex lock nut (Item 21). Ref. Diagram 8.

Diagram 8

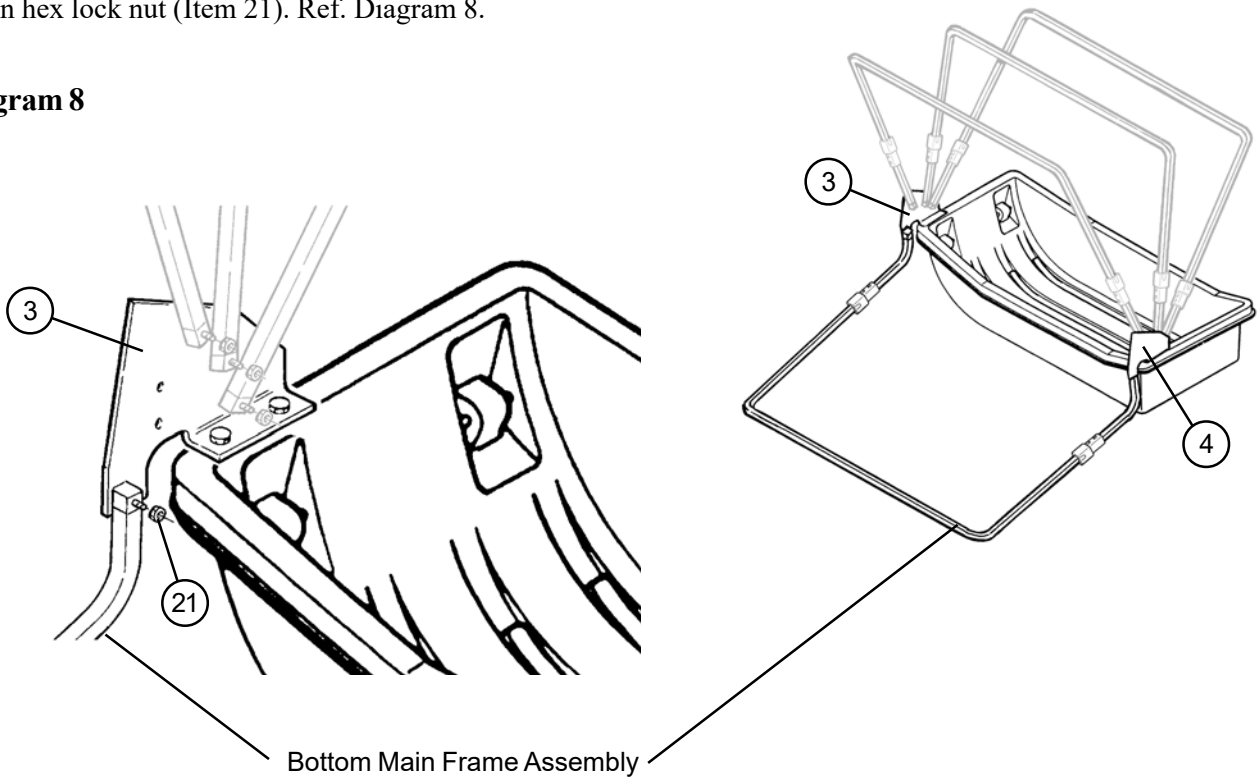

12. Set up main frame bars by grasping with both hands and pushing upward until button clicks into place. Start with bottom main frame bar and continue to the back main frame bar pushing lengthened bars into appropriate position (Ref. Diagram 9).

Diagram 9

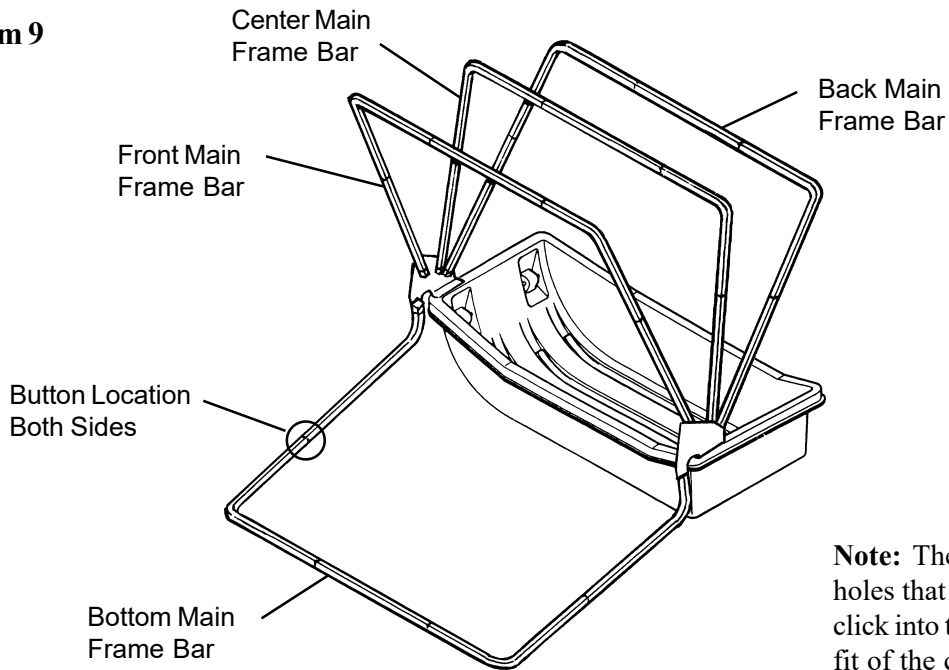

Note: There are two holes that the buttons can click into to optimize the fit of the canvas.

13. Install wind support bars starting in back (Item 5), up through center (Item 6), then between the front and center main frame bars (Item 7) and finally with adjustable wind support bar (Item 8) in front. Ref Diagram 10.

Diagram 10

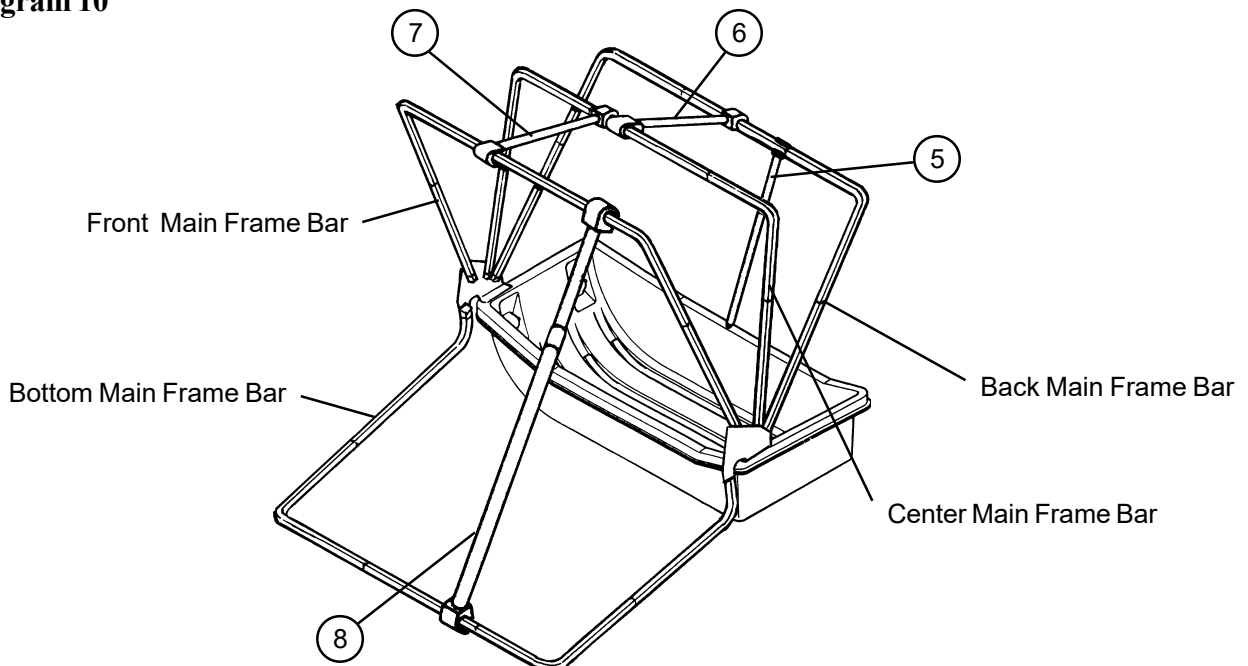

14. Slide the tent over the main frame bar assembly, then fasten the velcro straps on the inside of the tent to each main frame bar. Ref. Diagram 11.

Diagram 11

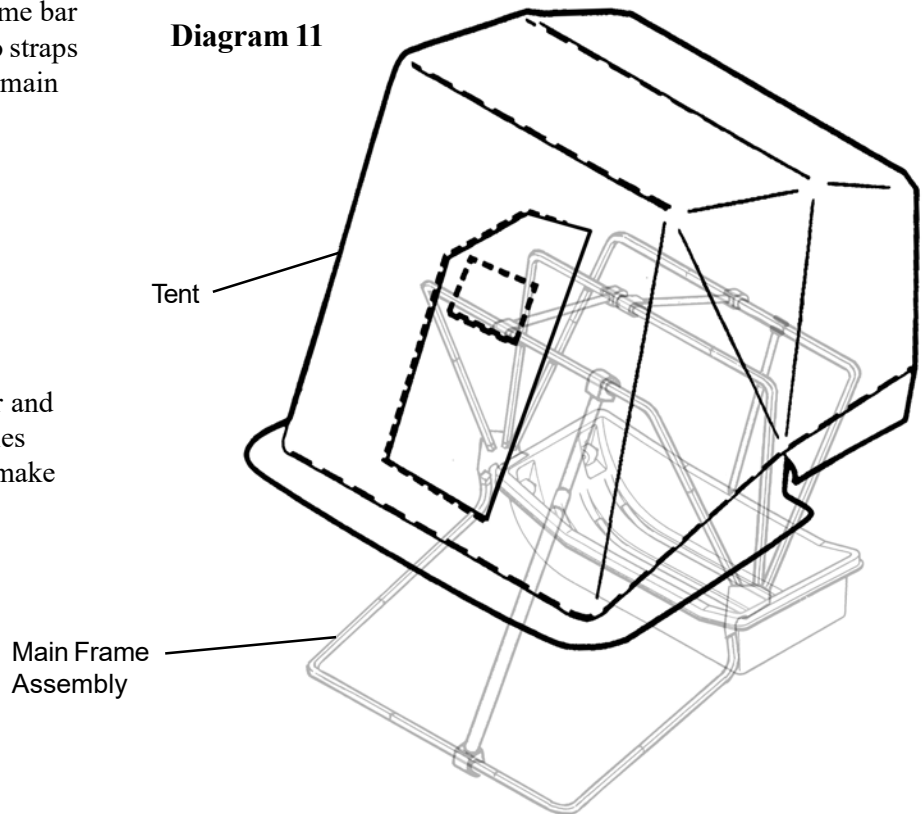

Note: Collapsing the center and front main frame poles part way down will make installation easier.

15. Once the canvas is on the frame and the Velcro attached, extend all of the frame poles upward and make sure all of the wind poles are installed. Extend the front adjustable wind pole so that the fabric in front is snug and not sagging. It will be necessary to loosen the back adjustable wind pole to achieve this. Once the front is set and the top wind poles are in place, the back adjustable wind pole can be extended until it is snug. Install the plastic trim lock in the positions shown in Diagram 12.

Install the back center trim lock first and work your way around the sled, pulling the fabric snug as you go. The canvas will be trapped between the sled lip and the trim lock, and will also wrap underneath the sled lip providing a very good seal. Check the fit of the canvas and adjust as necessary before installing the screws to hold the trim locks in place.

Attach the eight plastic trim locks (Item 25) to the sled in the locations shown with the 45° angled edge to the inside of the sled. Ref. Diagram 12.

Diagram 12

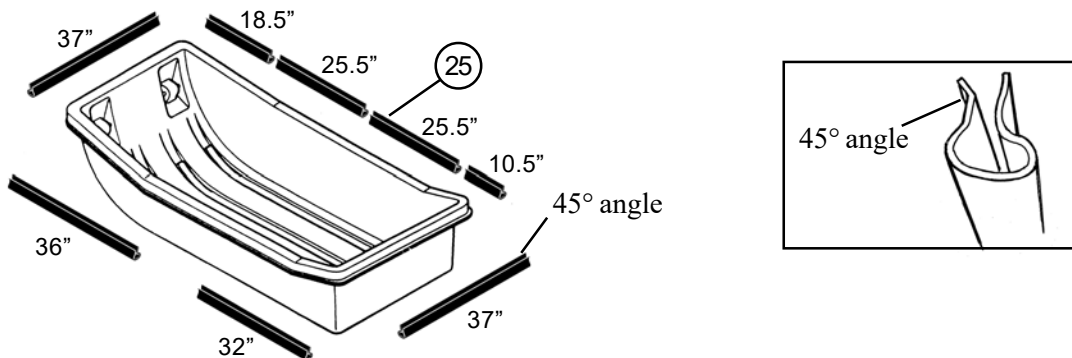

16. On the front of the fishhouse, start in the corners and work inward, snap the plastic trim seal over the tent skirt (Item 2) to the **lip** edge of the sled (Item 1). The tent skirt (Item 2) will meet in the middle and attach together. Ref. Diagram 13.

Diagram 13

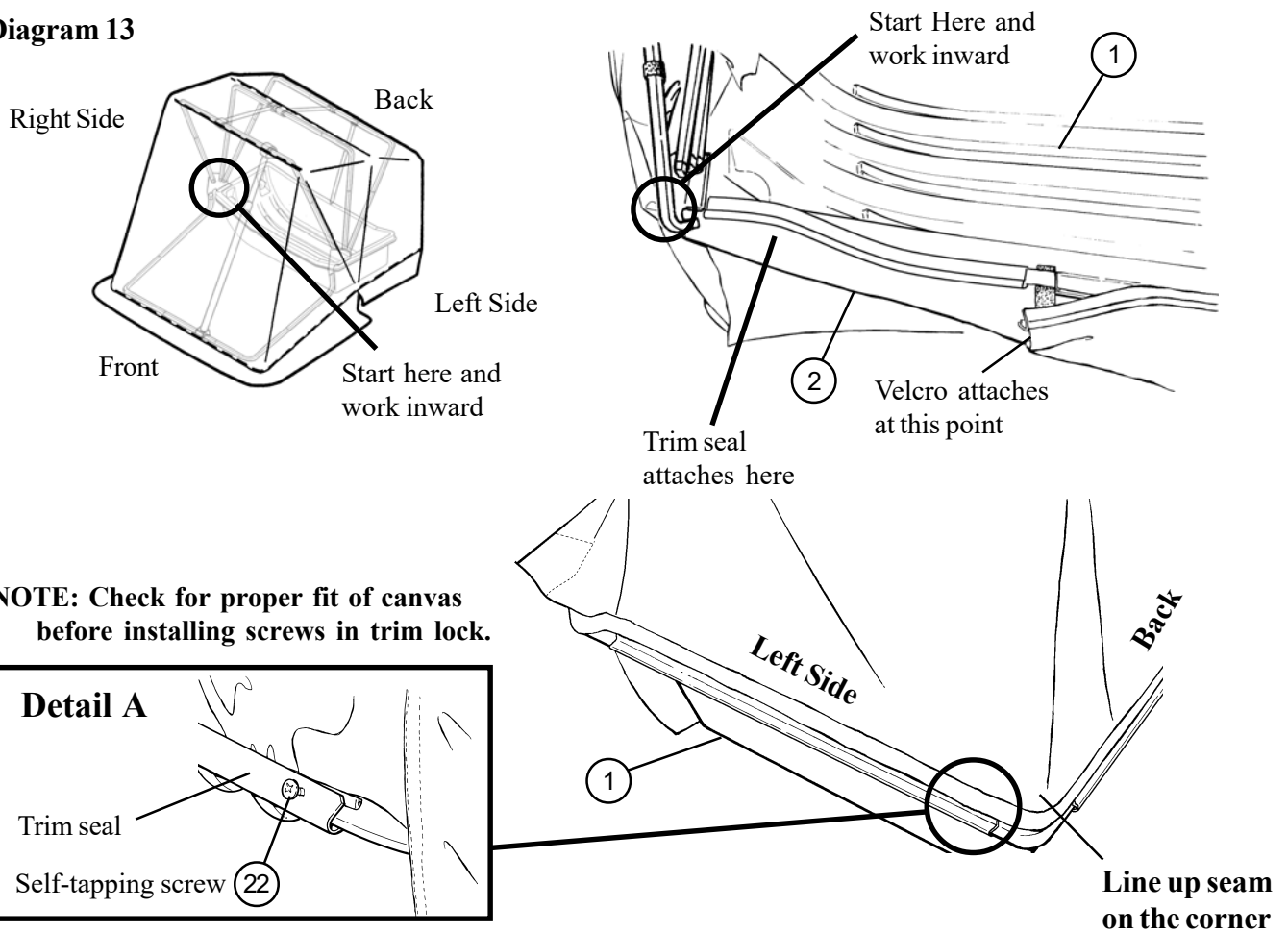

NOTE: Check for proper fit of canvas before installing screws in trim lock.

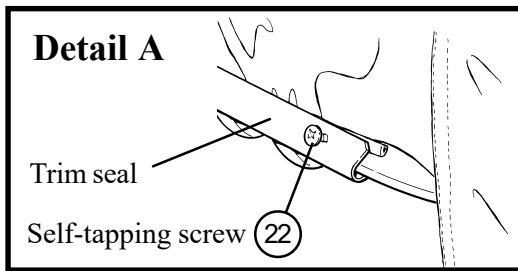

To Collapse Tent and Transport:

1. Remove support bars and store inside the sled.
2. Retract main frame bars by pressing in button while sliding the bar farther into the tube.
3. Fold the tent in towards the sled so all the bars are laying on top of the sled.
4. Tuck in excess tent material.
5. Ready for transport.
6. Reverse to set up the fishhouse again.

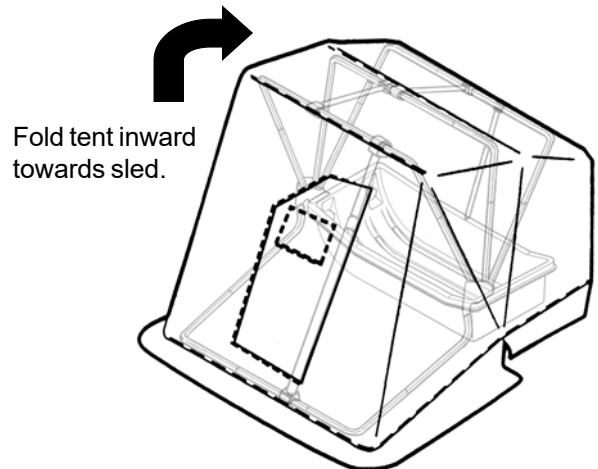

General Note: Be careful with tent windows in cold weather, as creasing or crushing them will cause breakage.



Caution: Use adequate ventilation. Portable heaters use up oxygen and emit carbon monoxide. Use reflectors and identifying lights after dark or during limited visibility.



Fish House Fabric Use and Care Guide

Care must be taken during use to avoid damaging the fabric. Follow these guidelines to help protect the fabric. The warranty will not cover damage to the fabric because of wear, improper packing or abuse.

1. Do not pack any gear on top of the fabric. Propane tanks and augers can be especially damaging because of the sharp edges and the extra weight associated with them.
2. When folding up the framework do not allow the fabric to be pinched between the hinge brackets and the frame poles.
3. Do not allow the fabric to be trapped between gear that is in the sled and the sled bottom. Gear that is sitting on top of the fabric will damage it due to vibration and impact.
4. Do not allow the fabric to come in contact with the heater or operate the heater too close to the fabric. The fabric can melt or the coating may be compromised from the heat.
5. When towing the fish house behind an ATV or snowmobile extra care must be taken because of the extreme amount of vibration and jarring that can occur. Padding or foam may need to be placed between the poles to protect the fabric. Any hard or sharp edge can damage the fabric if it is not padded or protected in some manner.
6. Do not pull on fabric that is frozen into the ice. This may damage the fabric or cause a seam to fail. Use a chisel to chop around the fabric to free it.
7. The fabric may be cleaned with warm water and a mild detergent if needed.
8. Always dry out the fabric after use and before storing.

By taking a few precautions to protect and maintain the fabric it will provide years of service.

